

# Product Information



## 4680IEP160P63

EAN 4031582307801

Swivel castor, housing made of very heavy pressed steel, reinforced, bright zinc plated, blue passivated, sealed swivel double ball bearing, reinforced and heat-treated ball covers, riveted king pin, wheel axle with nut. Wheel centre made of Aluminium, Tread: black elastic-tyre, vulcanized, precision ball bearing, plate fitting

Technical Data	
Wheel diameter	160 mm
Width of Tread	50 mm
Size of Plate	140 x 110 mm
Plate hole centres	105 x 80/74 mm
Plate hole	11 mm
Offset	55 mm
Swivel Interference	270 mm
Overall height	200 mm
Temperature	- 20 / + 85 °C
Standard	EN 12532
Weight	3.38 kg
Load capacity	350 kg
Load capacity (static)	700 kg
Swivel Radius	135 mm
Hardness of tread	A 67 Shore

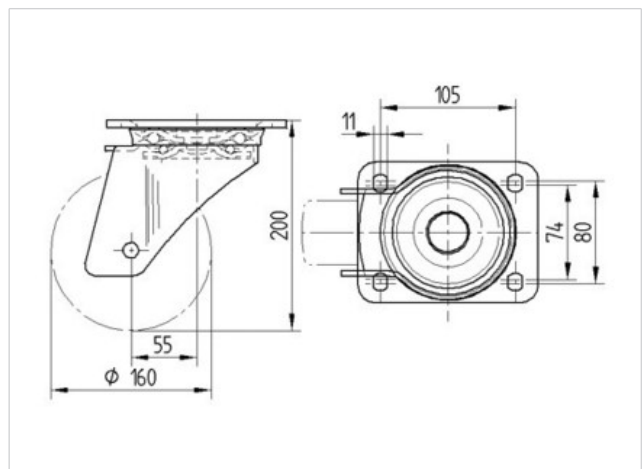

Roll performance	+	+	+	+	+
Movement noise	+	+	+	+	+
Attrition	+	+	+	+	+
Corrosion resistance	+	+	+	+	+

# Product Information



## 4680IEP160P63

EAN 4031582307801

